

DYNA-POWER LUBRICATION

TECHNICAL BULLETIN D-01-02-1

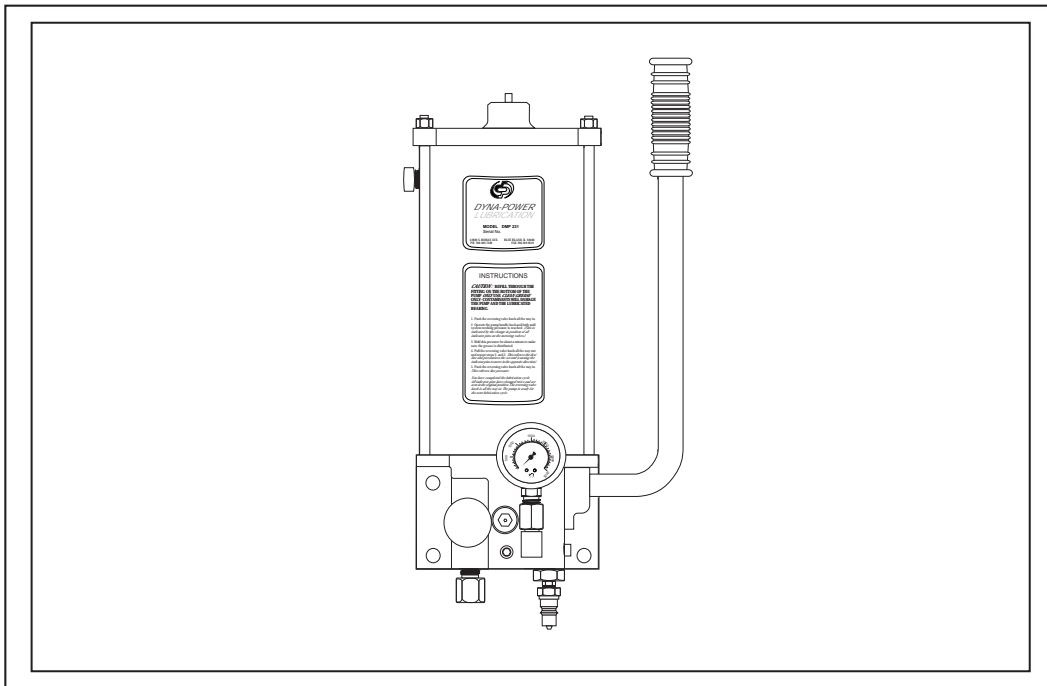

MANUAL PUMPS

Model No.:DMP 221,231,261



A division of
Dyna-Power Engineers, Inc.
PO Box 89 / 12809 S.Homan Ave.
Blue Island, IL 60406

JUNE 2000

TABLE OF CONTENTS:

General 1

Ordering Information 1

Operation /
Troubleshooting 2

Dimensional Data 3

Parts Breakdown
 Pump 4-5
 Reservoir 6

Adapter Plate 6

Parts List 7

FOR CUSTOMER SERVICE & APPLICATION HELP:

Dyna-Power Engineers
12809 South Homan Ave.
Blue Island, IL 60406

ph: (708) 389-7200 fax: (708) 389-9619

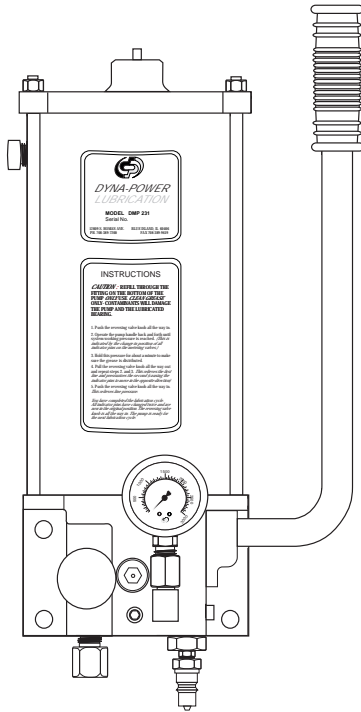

Model DMP231 shown here.

General

The DMP Manual Pump is a compact and reliable way of delivering lubricant. Manual pumps are most effective in applications that require relatively infrequent lubrication and have a low number of lubrication points. These pumps consist of a double-acting piston and a quick-fill fitting that allows for convenient filling of the reservoir.

In a dual line system, lubricant is directed from the pump alternately into one of two supply lines by means of a flow directional valve, controlled via the directional knob located on the pump.

Ordering Information

The DMP manual pump is offered in three reservoir sizes. The DMP is also available for oil use. Please call Dyna-Power for assistance.

Part No.	Description
DMP 221	Manual Pump (.53 gallon reservoir)
DMP 231	Manual Pump (0.8 gallon reservoir)
DMP 261	Manual Pump (1.6 gallon reservoir)

Specifications

Model	Discharge.cap./Stroke	Discharge.cap./Cycle*	Working Press. Max.	Reservoir cap./Type	Weight	Grease
DMP 221	.28 cu.in.	.56 cu.in.	3000 psi	0.53 gal/ plastic	35.2 lbs.	NLG1 #000 - #2
DMP 231				0.8 gal/ steel	44 lbs.	
DMP 261				1.6 gal/ steel	50.6 lbs.	

* Discharge cycle is the volume discharge by one back and forth operation of the pump handle.

Operation

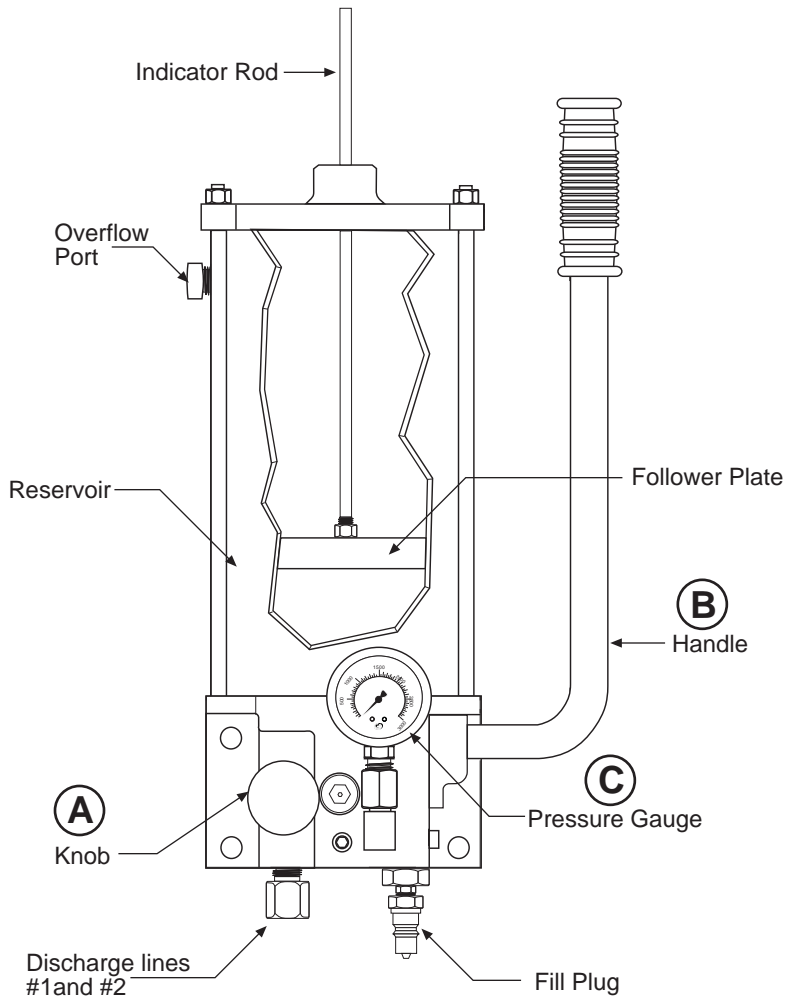

Operation:

1. Push in knob (A) all the way.
2. Operate pump handle (B) back and forth until the desired pressure is reached, as indicated on the pressure gauge (C).
3. Hold the specified pressure for a minute or two to make sure that lubricant is being delivered to all the necessary points.
4. Pull back the knob (A) fully and repeat steps 2 and 3.
5. Again push in the knob (A) fully in order to relieve line pressure.

Troubleshooting

1. If the pump handle does not seem to be offering the usual resistance and the pump does not build up pressure, this is usually a result of air in the reservoir. To remedy, clean out reservoir and place a small amount of oil in the bottom. Then refill the reservoir with clean grease **THROUGH THE FILL PLUG ONLY**.
2. If the pump handle springs back at the end of the discharge stroke or is locked in one position, this is an indication that the check valves (located on the bottom of the pump) are clogged -- probably as a result of contaminated lubricant. To remedy, clean out the reservoir and check valves (or replace if you still experience this problem after cleaning). Refill reservoir with **clean grease THROUGH THE FILL PLUG ONLY**.
3. If the pump pressure does not rise or the pump pressure rises suddenly, check the piping, measuring valves and any other connected valving for clogs or leaks.

Dimensional Data

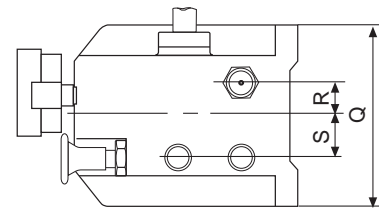
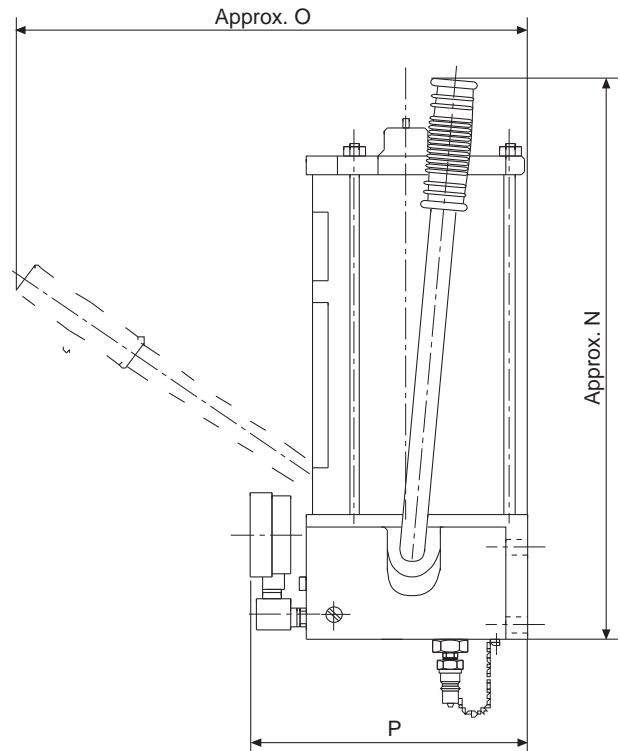
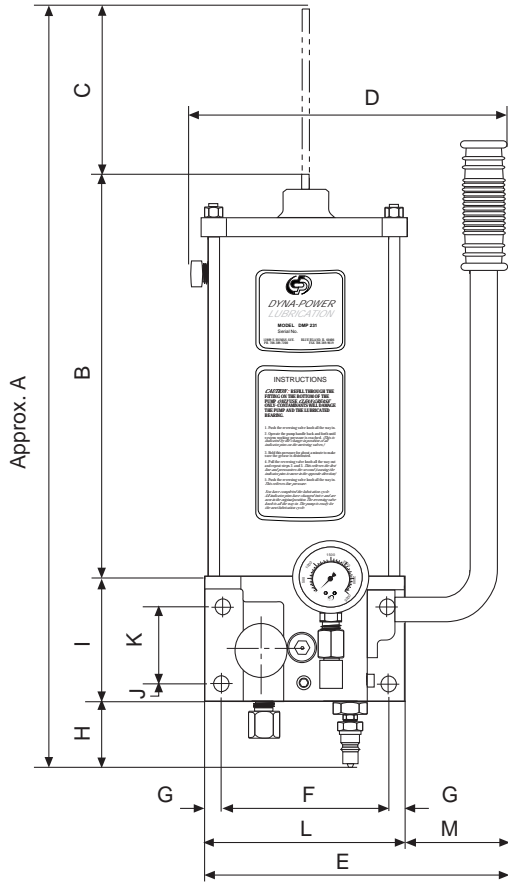

*The DMP221 reservoir (not shown here) is made of a transparent plastic and comes with a plastic follower. All DMP models use the same pump.

**Dimensions are in inches.

Model	A	B	C	D	E	F	G	H	I	J	K	L	M	N	O	P	Q	R	S
DMP221	18.35	11.67	NA	NA	8.96	4.88	.52	1.65	3.74	.39	2.36	5.91	2.95	16.69	15.12	8.19	5.91	1.06	1.26
DMP231	26.06	11.81	8.86	9.09	8.86	4.88	.52	1.65	3.74	.39	2.36	5.91	2.95	16.69	15.12	8.19	5.91	1.06	1.26
DMP261	43.78	20.67	17.72	9.09	8.86	4.88	.52	1.65	3.74	.39	2.36	5.91	2.95	16.69	15.12	8.19	5.91	1.06	1.26

PARTS BREAKDOWN-Pump Assembly

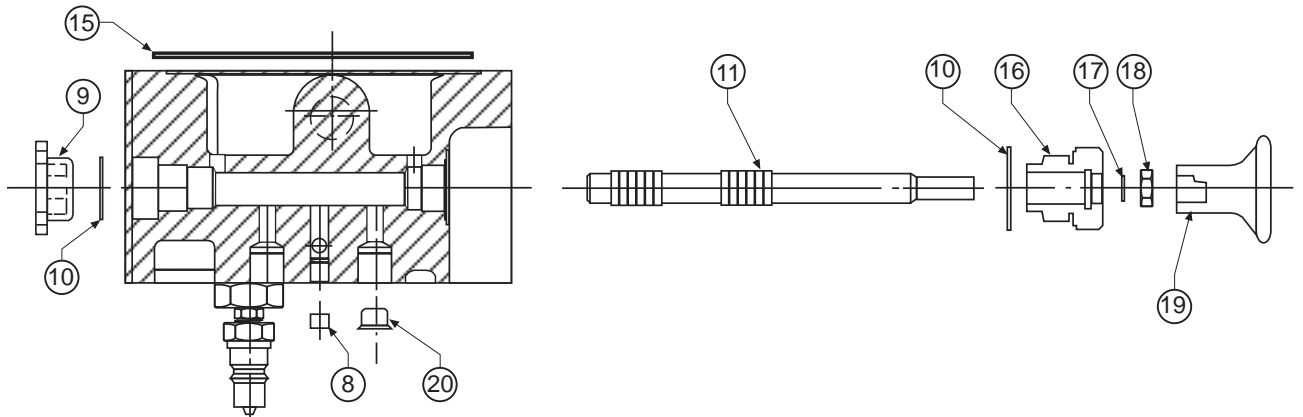
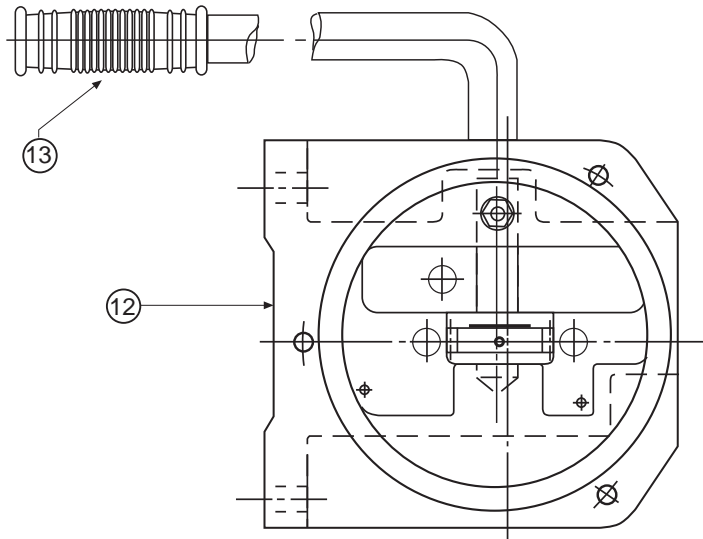
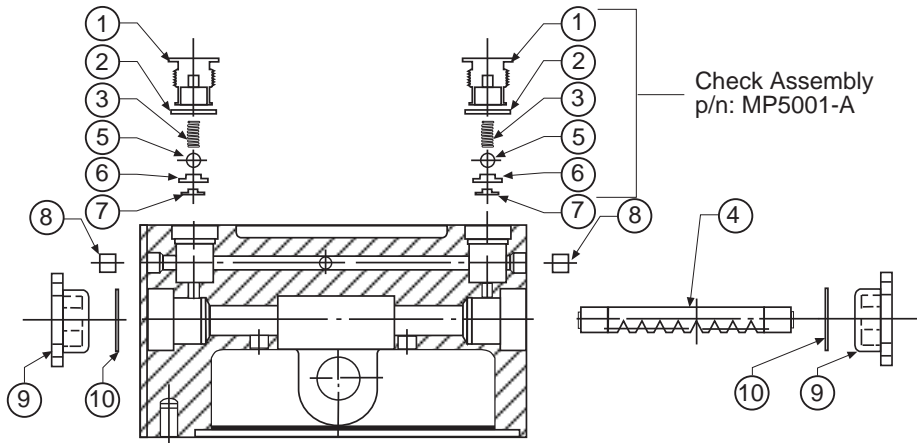

PARTS BREAKDOWN-Pump Assembly

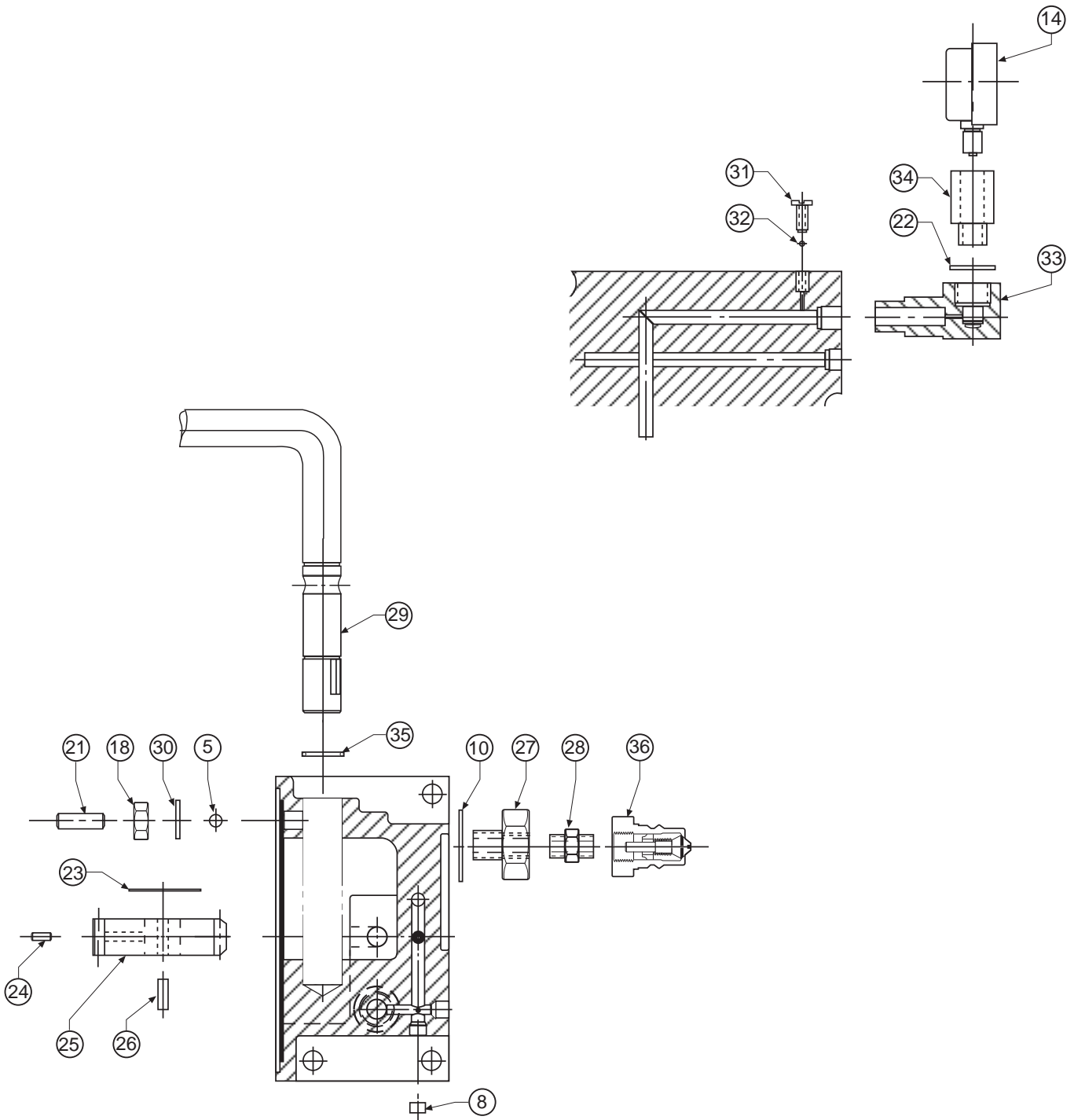

PARTS BREAKDOWN-Reservoir Assemblies

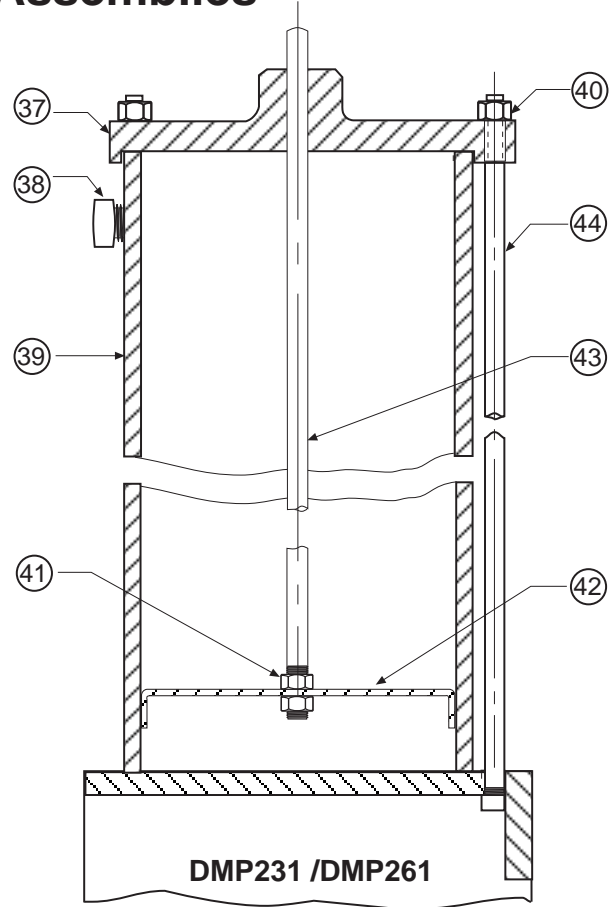
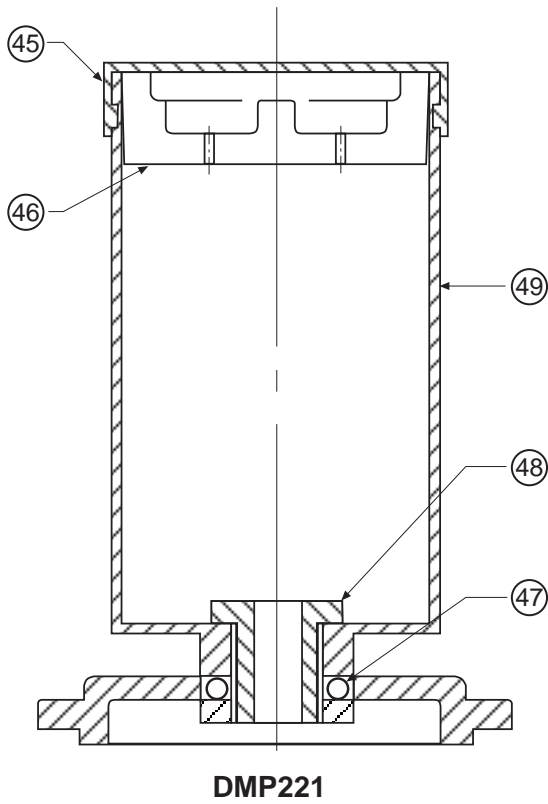

Adapter Plate

The AP231 adapter plate was designed for the DMP231 and DMP 261 to fit Farval's mounting dimension's for ease of replacement.

The adapter plate should be ordered separately.

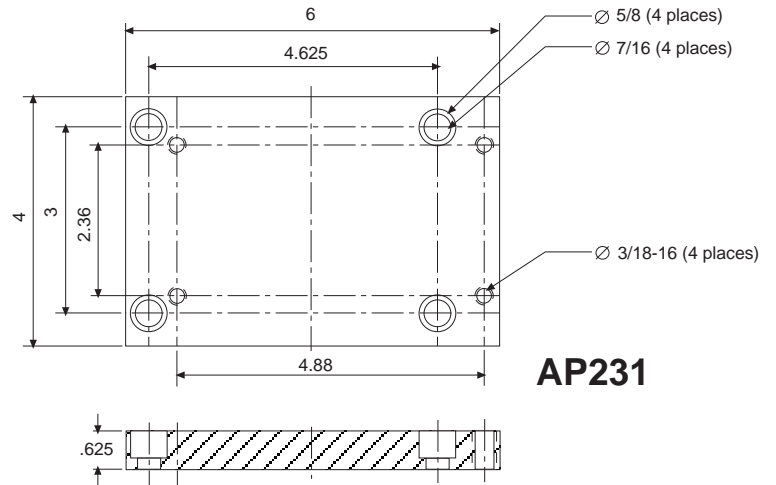

PARTS BREAKDOWN

Item	Part No.	Qty.	Description	Item	Part No.	Qty.	Description
1	MP1001-A	2	CHECK BODY	27	MP1102-A	1	ADAPTER
2	MP1108-A	2	O-RING	28	P010-4	1	NIPPLE
3	MP1004-A	2	SPRING	29	MP8001-A	1	HANDLE
4	MP8006-A	1	RACK	30	MP3006-A	1	WASHER
5	MP2005-A	3	STEEL BALL	31	MP9004-A	1	BLEED SCREW
6	MP1003-A	2	SEAT	32	MP2001-A	1	STEEL BALL
7	MP1002-A	2	SEAT	33	MP8007-A	1	ELBOW
8	MP5001-A	4	PLUG	34	F40HGS	1	ADAPTER
9	MP2012-A	3	PLUG	35	MP1112-A	1	O-RING
10	MP3013-A	5	WASHER	36	QHP4	1	COUPLING
11	MP1005-A	1	PISTON	37	MP9100-A	1	COVER
12	MP1000-A	1	PUMP BODY	38	MP9101-A	1	OVERFLOW VALVE
13	MP8002-A	1	HANDLE GRIP	39	MP9102-A	1	RESERVOIR (DMP 231)
14	D902D	1	PRESSURE GAUGE		MP9200-A	1	RESERVOIR (DMP 261)
15	MP3003-A	1	GASKET	40	MP9103-A	3	NUT
16	MP9002-A	1	BUSHING	41	MP9104-A	2	NUT
17	MP1106-A	1	WASHER	42	MP9105-A	1	FOLLOWER PLATE
18	MP2006-A	2	NUT	43	MP9106-A	1	INDICATOR ROD (DMP 231)
19	MP9003-A	1	KNOB		MP9202-A	1	INDICATOR ROD (DMP 261)
20	MP4003-A	1	CAP	44	MP9107-A	3	TIE ROD (DMP 231)
21	MP1350-A	1	SET SCREW		MP9203-A	3	TIE ROD (DMP 261)
22	MP3004-A	1	WASHER	45	MP9300-A	1	COVER
23	MP2309-A	1	RETAINING RING	46	MP9305-A	1	FOLLOWER PLATE (DMP221)
24	MP1333-A	1	SET SCREW	47	MP9301-A	1	O-RING
25	MP8003-A	1	PINION	48	MP9302-A	1	MTG ADAPTER
26	MP4401-A	1	KEY	49	MP9306-A	1	RESERVOIR (DMP 221)

Notes: